



MASON INDUSTRIES, Inc.
Manufacturers of Vibration Control Products

350 Rabro Drive
Hauppauge, NY 11788
631/348-0282
FAX 631/348-0279
Info@Mason-Ind.com
www.Mason-Ind.com

2101 W. Crescent Ave., Suite D
Anaheim, CA 92801
714/535-2727
FAX 714/535-5738
Info@MasonAnaheim.com
www.MasonAnaheim.com

**SPOOL TYPE
ACOUSTICAL
PIPE SEALS**

SPS

DATA SHEET DS-632-1

SPS

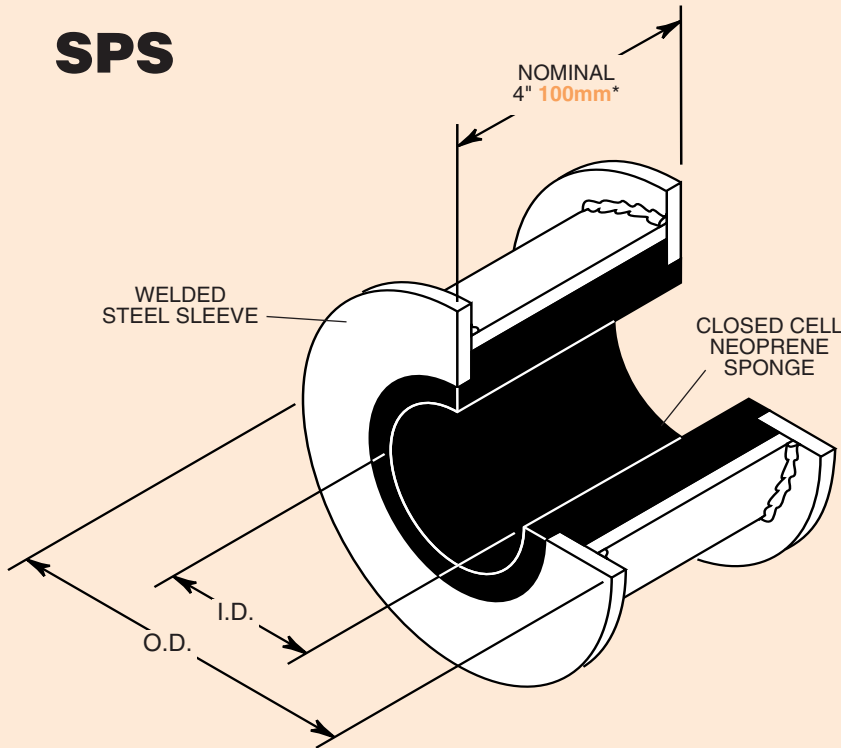

*Spools may be made longer on request

The problem of establishing a sound seal around piping passing through walls, floors and ceilings has always been difficult. Normally a sleeve is left in the opening and the pipe passed through later. The periphery is eccentric, so fiberglass packing becomes makeshift and caulking even more nebulous. Only a skilled, supervised worker can do the job properly. The SPS spool type pipe seal is a simple positive device that does an excellent job and presents a neat appearance. Installation is simple as described below.

INSTALLATION PROCEDURE

If pipe is to be installed before wall construction:

1. Slide SPS onto pipe.
2. Hang pipe.
3. Build or pour wall around SPS, caulk any cracks.

If pipe is to be installed in hole in wall:

1. Slide SPS onto pipe.
2. Pass pipe thru hole and position SPS in hole.
3. Pack concrete around SPS and caulk any cracks.

If pipe is to be installed thru SPS cast into wall:

1. Cast SPS into wall as wall is being built.
2. Slide pipe thru SPS.
3. Caulk any cracks.

TYPE SPS DIMENSIONS

Metric Dimensions

SPS Size	Spool Piece For Pipe Size (in)			Spool Piece For Pipe Size (mm)		
	I.D. (in)	O.D. (in)		I.D. (mm)	O.D. (mm)	
50	1/2	7/8	4	13	21	102
75	3/4	11/16	4	20	26	102
100	1	13/8	4 3/4	25	35	120
125	1 1/4	1 11/16	5	30	42	125
150	1 1/2	1 7/8	5 1/4	40	48	132
200	2	2 3/8	5 1/2	50	60	139
250	2 1/2	2 7/8	6 1/2	65	72	164
300	3	3 1/2	7 3/4	75	88	195
350	3 1/2	4	7 3/4	90	102	195
400	4	4 1/2	7 3/4	100	114	195
500	5	5 9/16	9 3/4	125	141	248
600	6	6 5/8	9 3/4	150	168	248
800	8	8 5/8	11 3/4	200	218	298
1000	10	10 3/4	15	250	273	381
1200	12	12 3/4	17	300	323	432